

ROTARY-PRO

Simple. Rugged. Affordable.™

Rotary Parts Accumulator



THE ROTARY-PRO is a stand-alone parts handling system designed to safely convey and collect finished components from all types of CNC machines, requiring no machine interface or specialist training to operate.

- Large volumes of components can be stored safely with no damage to parts allowing CNC machines to run unattended for prolonged periods, ideal for overnight production.
- The Rotary-Pro “soft handles” finished components on high lubricity plastic to minimize friction and keep parts safe from damage.
- Electrical power can be supplied from an independent supply or from any Lexair bar feed system.

Model RP-48

Lexair, Inc.

Problem Solved.™

www.lexairinc.com



A soft non-slip sprocket driven conveyor safely handles the parts onto the rotary table.



Easy and quick set-up with 3 simple commands for operator to follow.



Adapt to your needs with left or right-hand operation.

ROTARY-PRO

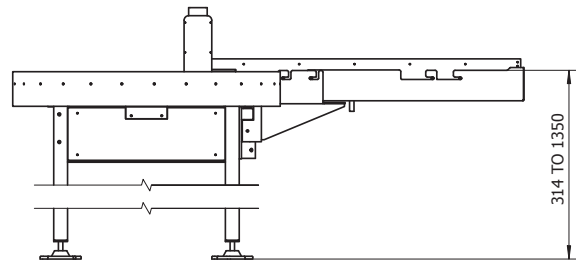
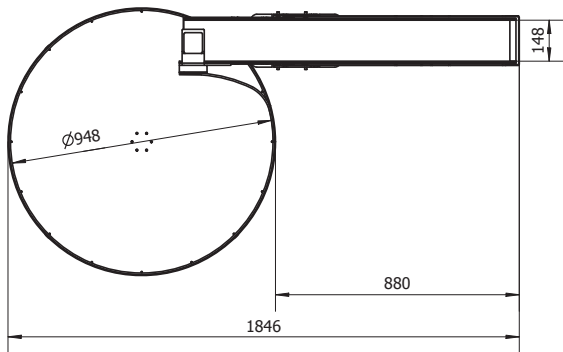

Rotary-Pro Standard Features

- Interactive touch screen
- Fully programmable
- Standalone control box which can be operated from the lathe programming position
- Conveyor can be adjusted by operator to suit LH or RH applications
- Timer driven index for both conveyor and rotary storage table
- Hard wearing gear-driven conveyor belt
- Manufactured from a welded frame of 50mm x 50mm steel box section
- Conveyor coolant drip tray easily removed by operator
- Excess coolant is drained back to machine coolant tank
- No machine tool interface required
- Can be moved from one machine to another
- 1-year warranty

Options

- Can be supplied without a conveyor
- Standalone conveyor
- Special length conveyor
- Removable bucket segments to collect your finished components
- Customer specific indexing
- Safety guarding and access steps for high level machine conveyor
- Power your Rotary-Pro from a Lexair Barfeed
- Color matching to customer specifications
- Casters
- Custom systems



Problem Solved.™

www.lexairinc.com

2025 Mercer Road
Lexington, KY 40511
Phone: 859-255-5001
Fax: 859-255-6656