

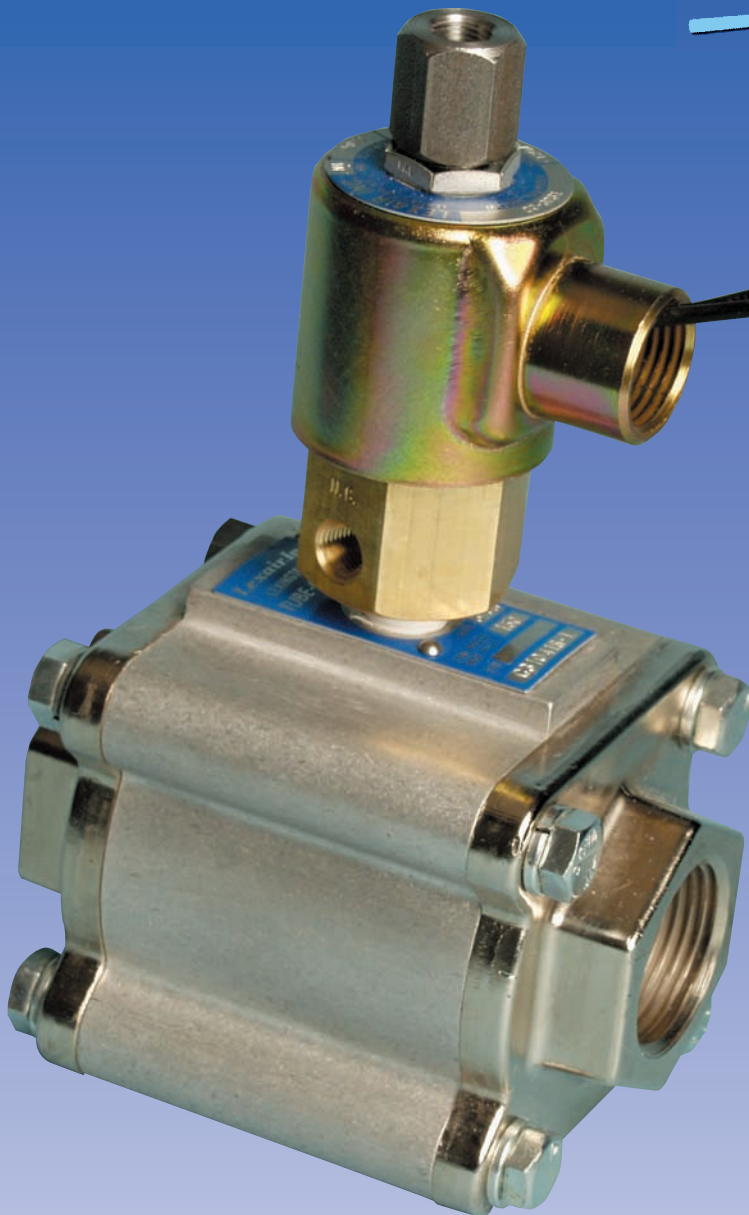

TUBEOMATIC®

Specially Designed
for Abrasive and
Corrosive
Applications



- 1/4" to 2 1/2" Remote Control Shut-Off Valves
- Solves Problems of Wear and Maintenance in Abrasive and Corrosive Media
- No Spools, Poppets or Sliding Seals That Can Wear or Stick
- Available with Solenoid and Pilot Actuators

Valves for Abrasive and Corrosive Liquids and Gases to 150

Pinch Valve Concept

The TUBE-O-MATIC has been designed to include the excellent features of the pinch valve without the inherent weaknesses. The TUBE in the TUBE-O-MATIC does not collapse entirely as the tubing does in a pinch valve. The TUBE-O-MATIC closes on the airfoil center core. Thus the movement of the TUBE is substantially reduced, resulting in extended TUBE life.

Bi-Directional

The normally open TUBE-O-MATIC valve design allows media flow in both directions. This feature can prove invaluable in systems requiring both forward and reverse control.

How It Works

The TUBE-O-MATIC tube is controlled by an external pneumatic or hydraulic pilot pressure. To close the valve, pilot pressure is applied, closing the tube around the center core and sealing bubble tight. To open the valve, pilot pressure is exhausted. The small tube deflection permits a high cycle rate, with minimal flow noise and shock-free smooth opening or closing on fluids.



Straight-Thru Flow

This type of flow pattern eliminates the build-up of solids in the valve body. It acts as a self-flushing unit.

Large-Capacity

With a Cv range of 4.0 to 75.0 and pipe sizes available from 1/4" NPT to 2 1/2" NPT TUBE-O-MATIC has a valve to fit your application. The airfoil design of the center core and the straight-through flow pattern result in capacity which compares to ball valves.

Minimum Wear

The only moving part in the TUBE-O-MATIC is the tube and that movement is held to a minimum, by the center core tube support design, giving a long trouble-free life.

TUBE-O-MATIC Valve Construction

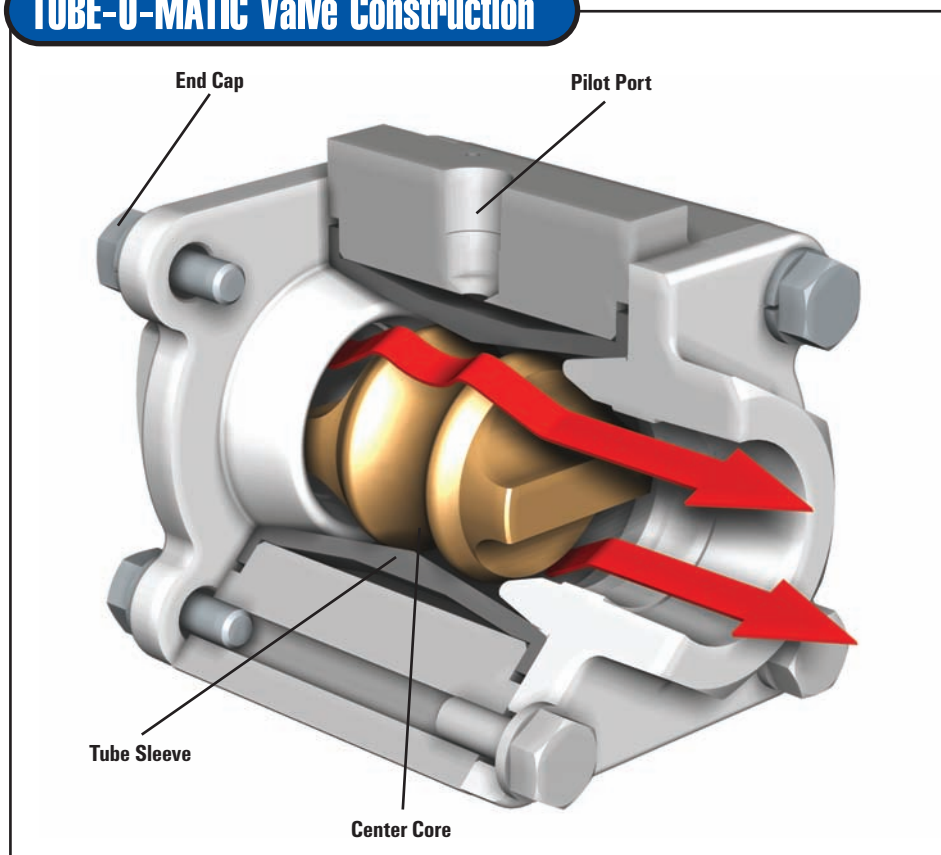

Model Numbers

Port Size N.P.T.	Solenoid Model	Pilot Model	Flow CV	Weight, lbs.	
				Sol.	Pilot
1/4	310404	310204	4.0	4 1/2	3 1/2
3/8	310406	310206	4.3	4 1/2	3 1/2
1/2	310408	310208	4.6	4 1/2	3 1/2
3/4	310412	310212	14.0	7 1/2	6 1/2
1	310416	310216	15.0	7 1/2	6 1/2
1 1/4	310420	310220	34.0	15	14
1 1/2	310424	310224	36.0	15	14
2	310432	310232	65.0	27 1/2	26 1/2
2 1/2	310440	310240	75.0	27 1/2	26 1/2

Solenoid Selectors

-X	Voltage/Hz
-1	120V/60Hz
-2	240V/60Hz
-3	480V/60Hz
-4	6V-DC
-5	12V-DC
-6	24V-DC
-7	24V/60Hz

Material Selection*

Options indicated by number—Add to Model Number

	Temperature Range	1/4 - 3/8 - 1/2	3/4 - 1	1 1/4 - 1 1/2	2 - 2 1/2
Center Core					
Brass, (Nickel Plated)		Std.	Std.	Std.	N/A
Aluminum, (Nickel Plated)		N/A	N/A	N/A	Std.
PVC	0 - 150° F	43	43	C/F	C/F
316 Stainless		45	45	C/F	C/F
Teflon		46	46	46	46
End Caps					
Bronze, (wetted surfaces, Nickel Plated)		Std.	Std.	Std.	Std.
316 Stainless		59	59	C/F	C/F
PVC	0 - 150° F	57	57	C/F	C/F
Tube					
Buna N	-20 - 200° F	Std.	Std.	Std.	Std.
Viton	0 - 400° F	26	26	26	26
Ethylene Propylene	-20 - 300° F	29	29	29	29
Solenoid Protector					
J.I.C. Housing		55	55	55	55
X-proof		51	51	51	51
Brad Harrison Connector		53	53	53	53

Standard options shown. Consult factory for solenoid and coil modifications, and special material, which are available on special quote.

Maximum Media Pressure

- 150 PSI solenoid/pilot
- Solenoid valve is multi-purpose rated at 150 PSI applied to either normally open or normally closed port

Note: Minimum pilot to media ratio is 1:1. For maximum TUBE life the pilot to media pressure differential should not exceed 20 PSI. For line pressures below 50 PSI, pilot pressure must be line pressure + 15 PSI.

How To Order

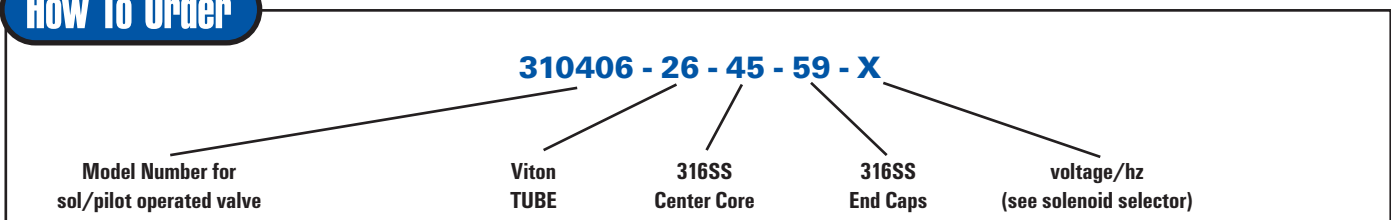

Lexair® Valves for Every Application

Valves for Abrasive and Corrosive Liquids and Gases to 150 PSI



Applications:

TUBE-O-MATIC valves are used on machine tools, in chemical plants, on sandblasting equipment, on food processing machines, on paper processing equipment, fluid reclamation systems, and anywhere else where corrosive or abrasive materials are the media.

Dimensions (inches)

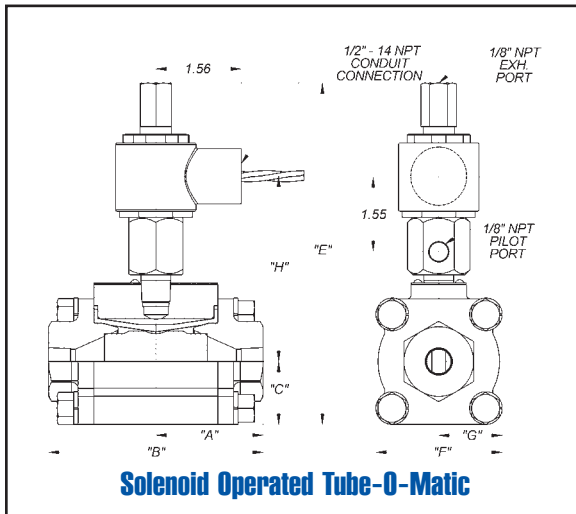

Solenoid Operated Tube-O-Matic

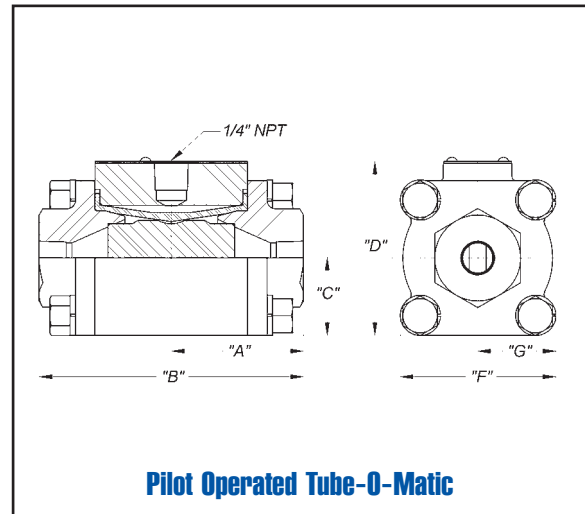

Pilot Operated Tube-O-Matic

NPT Port Size	Solenoid Pilot Model	Direct Pilot Model	Overall Dimensions							
			A	B	C	D	E	F	G	H
1/4	310404	310204	1.94	3.88	1.13	2.50	6.40	2.25	1.13	3.06
3/8	310406	310206	1.94	3.88	1.13	2.50	6.40	2.25	1.13	3.06
1/2	310408	310208	1.94	3.88	1.13	2.50	6.40	2.25	1.13	3.06
3/4	310412	310212	2.16	4.31	1.50	3.19	7.08	3.00	1.50	3.31
1	310416	310216	2.16	4.31	1.50	3.19	7.08	3.00	1.50	3.31
1 1/4	310420	310220	3.31	6.63	2.00	4.19	8.08	4.00	2.00	4.19
1 1/2	310424	310224	3.31	6.63	2.00	4.19	8.08	4.00	2.00	4.19
2	310432	310232	4.41	8.81	2.88	5.81	9.71	5.75	2.88	4.94
2 1/2	310440	310240	4.41	8.81	2.88	5.81	9.71	5.75	2.88	4.94



2025 Mercer Road
Lexington, KY 40511-1018
859-255-5001
859-255-6656 Fax
www.lexairinc.com



National
FLUID POWER
Association

MEMBER

Catalog LX-45-A
Revised 4/12